

# Shaping, Tubular Knitting, and Illusion Knitting

# Recap:

- basic knitting
- colorwork techniques
- laces
  - transfer planning algorithms
  - knitting program efficiency

# Agenda Today

- How to create non-flat structures?
  - What are some ways that can create non-flat knits?
- Shaping
- Tubular knitting
- “Illusion knitting”

# Knit Shaping



We want to change the number of loops in a given row (course) of knitting and in a given column (wale)

# Shaping Operations: Decrease

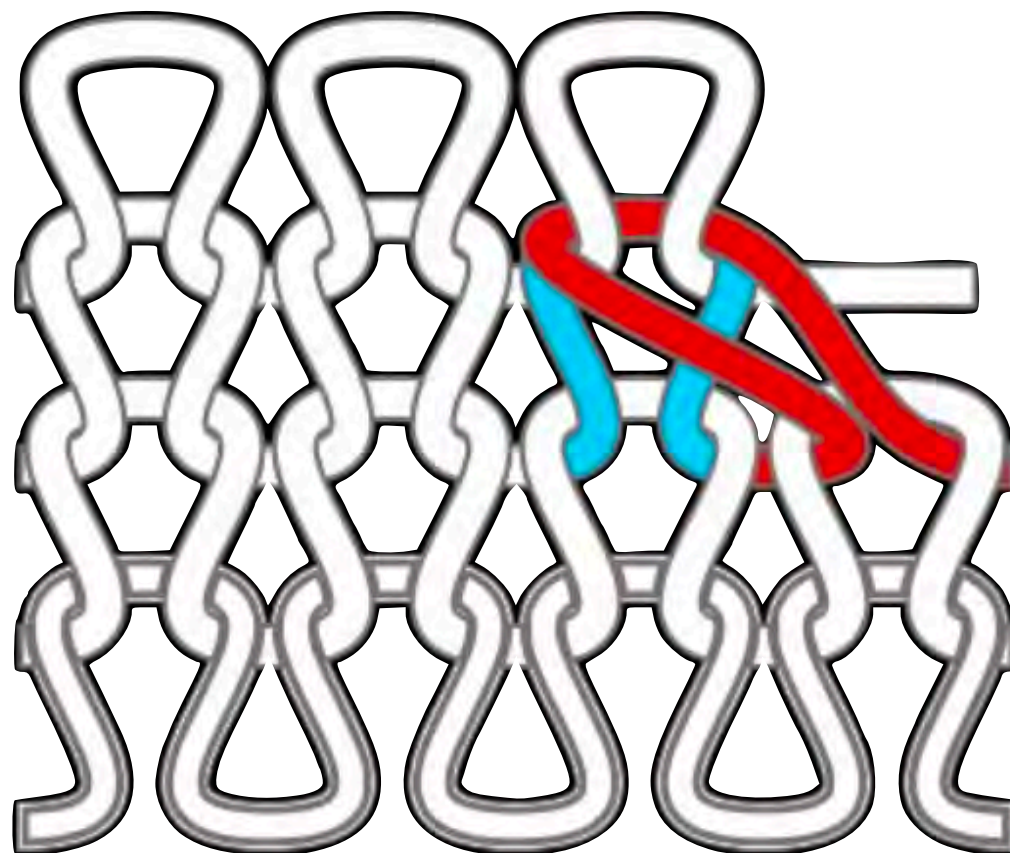



# Recap: Transfers

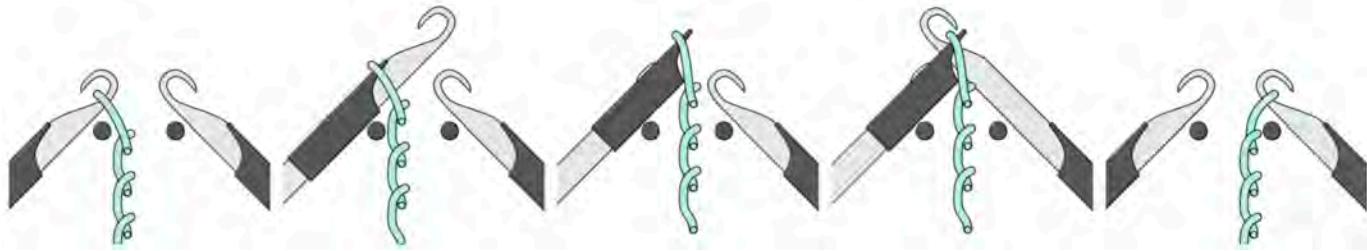

Back Bed

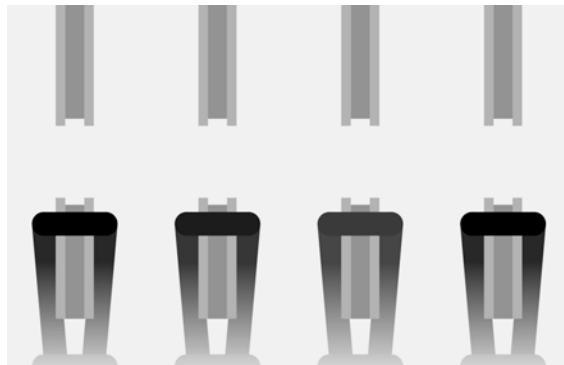

Front Bed

**Transfers move loops from  
a needle to the needle  
across from it**

**xfer f3 b3**

**xfer b3 f3**

# Recap: Stacking Loops

xfer f2 b2  
rack 1  
xfer b2 f3



xfer f3 b3  
rack -1  
xfer f2 b3  
rack 0  
xfer b3 f3

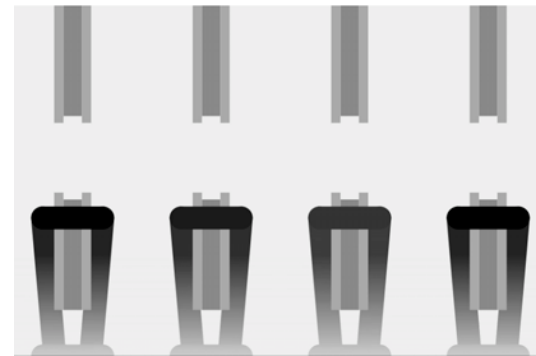

**Remember! Once two loops are on the same needle, they're stuck together forever!**

# Shaping Operations: Increase

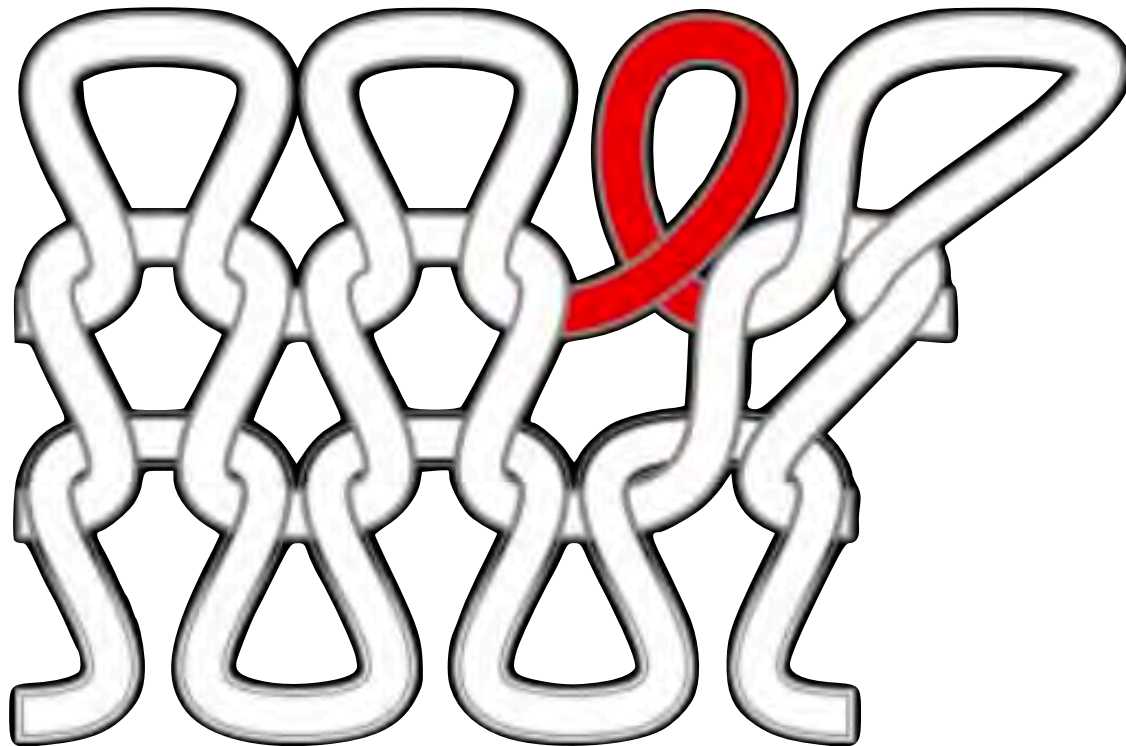

# Increase is local widening

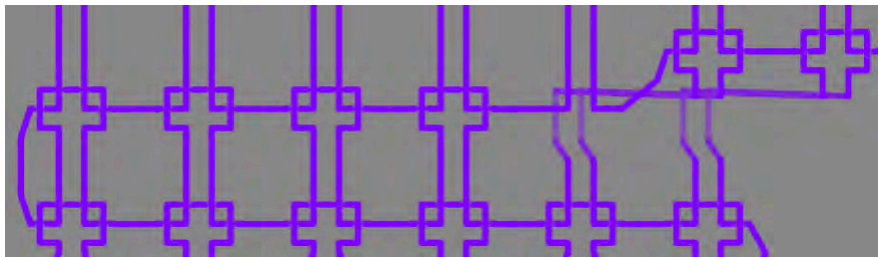

1. Decide where you want the increase to be
2. Transfer loops over to leave that needle empty
3. Knit through loops and fill in the empty needle

miss + f2 1  
knit - f2 1  
miss + f2 1

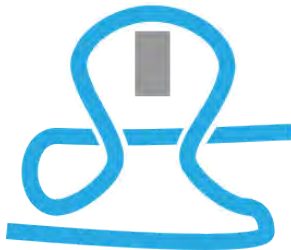

twisted tuck increase  
(here the knit is the same as the tuck)

split + f2 b2 1  
rack 1  
xfer b2 f3

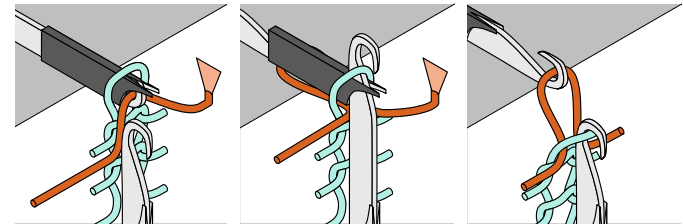

split increase

# The default tuck increase

```
knit - f7 1  
knit - f6 1  
tuck - f5 1 ;; equivalent to knit  
knit - f4 1  
knit - f3 1  
knit - f2 1  
knit - f1 1
```

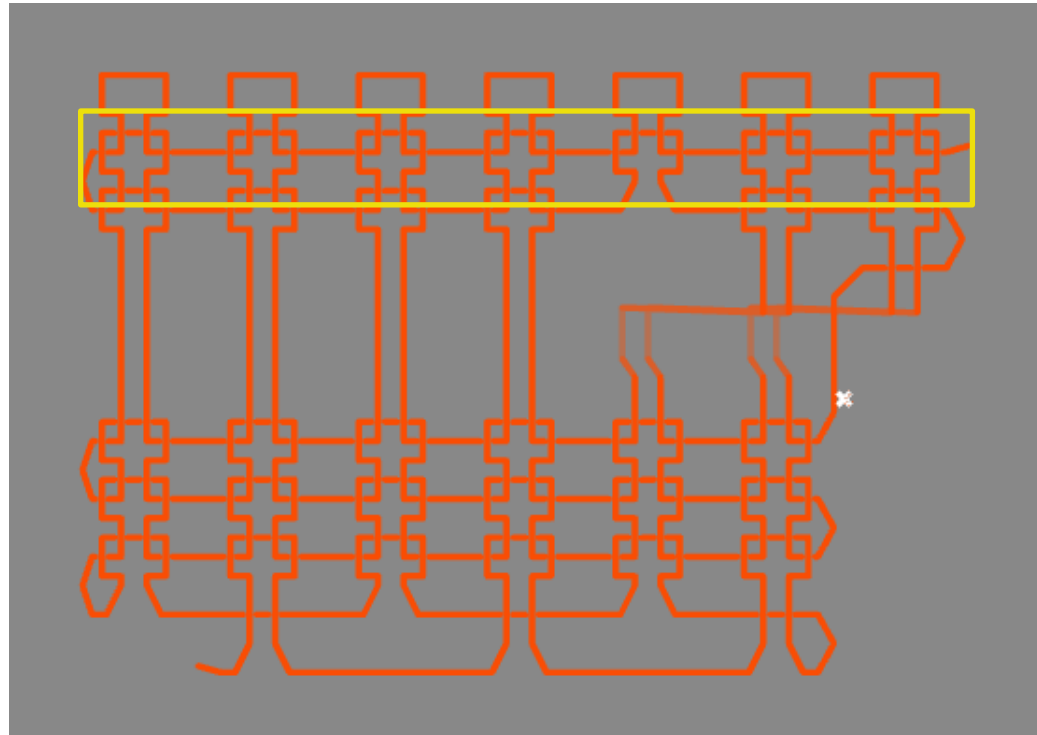

**This leaves a hole but it could be a feature (e.g., for lace patterns)**

# Shaping Operations: Short Rows

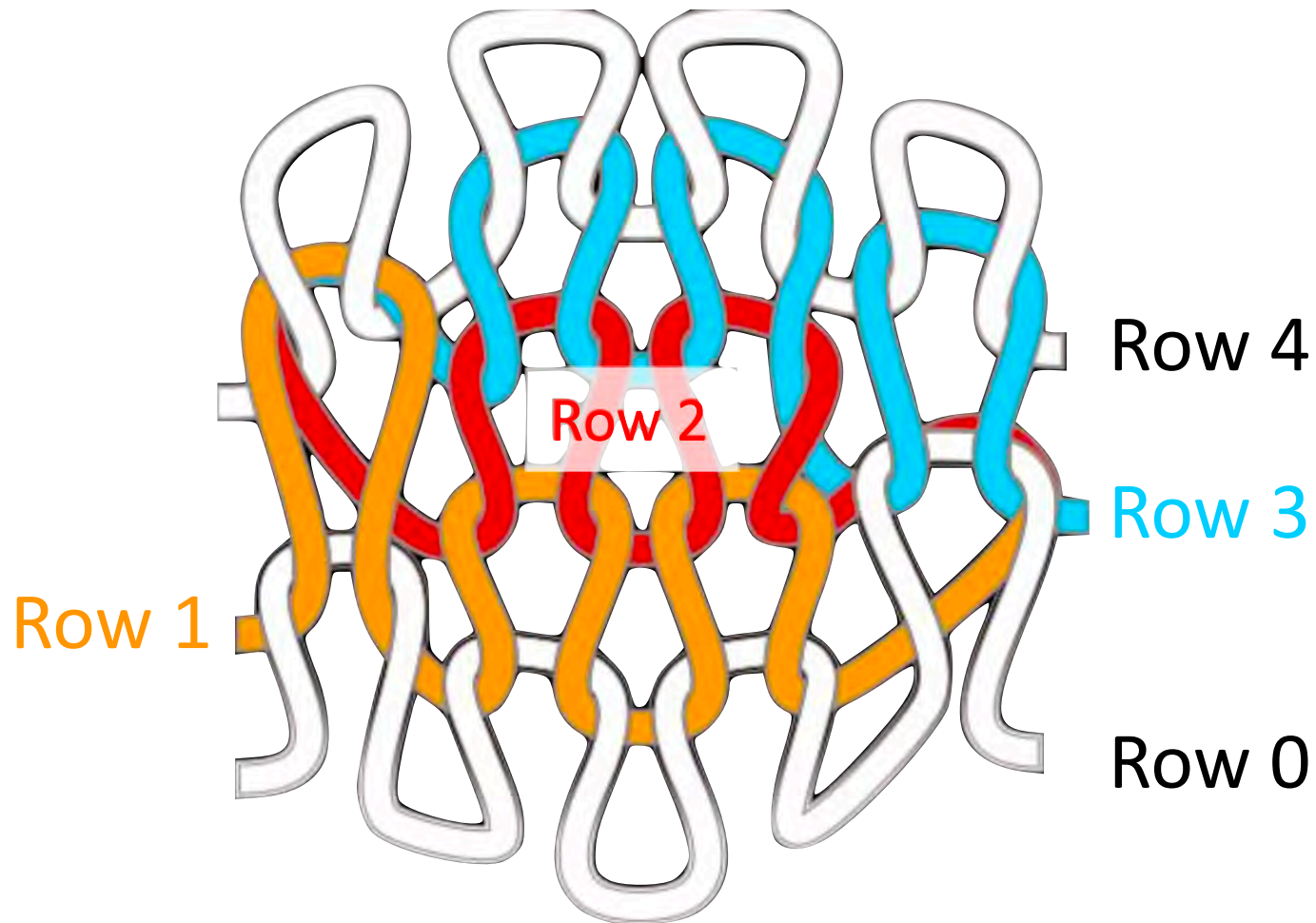

# Short-rows is local lengthening

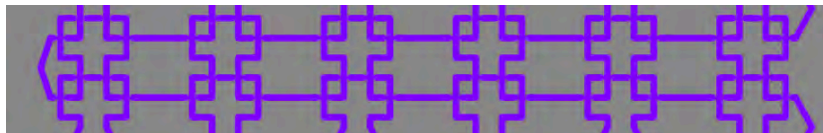

**Just turning  
around makes a  
disconnected  
“handle”**

# Short-rows is local lengthening

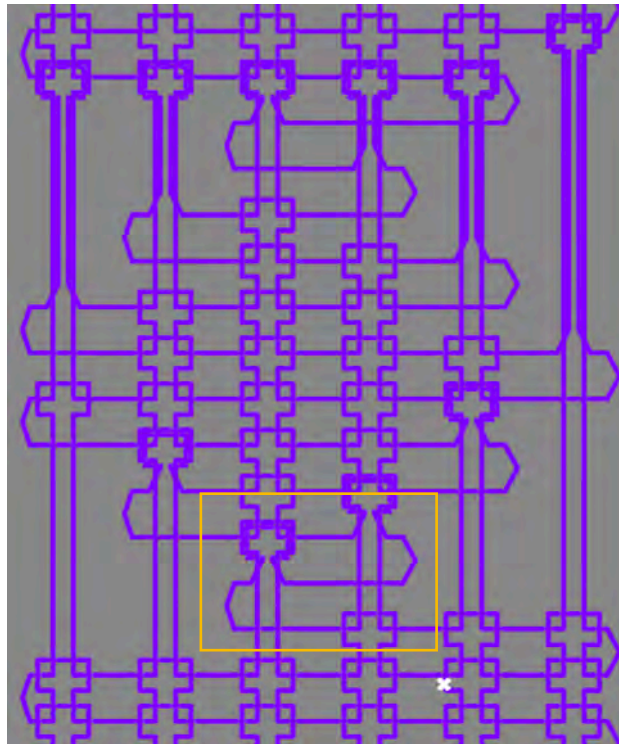

knit - f4 6  
tuck + f3 6  
tuck - f4 6  
knit - f3 6



1. Add tucks to secure edges of fabric together
2. Short row gradually to avoid bunched up fabric

# What avoids the local build-up in short rows?

- Takedown mechanisms
  - sinkers: non-uniform takedown
    - better for short-rows
  - rollers: uniform takedown
    - worse for short-rows

# Sinkers

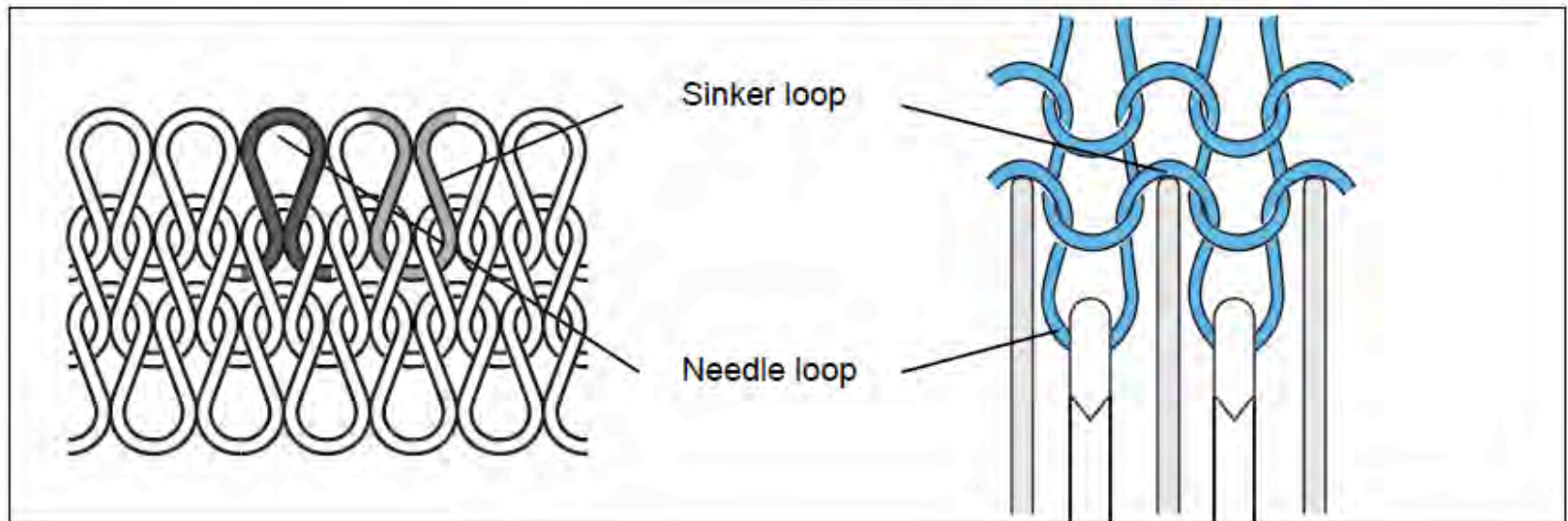
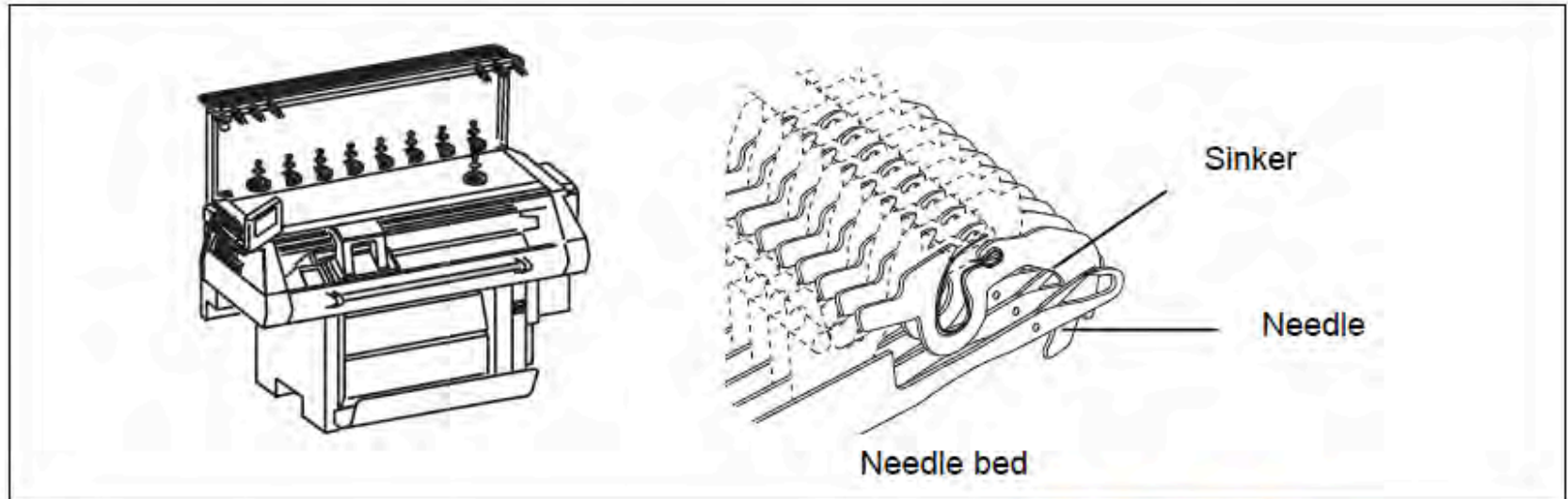

# Rollers

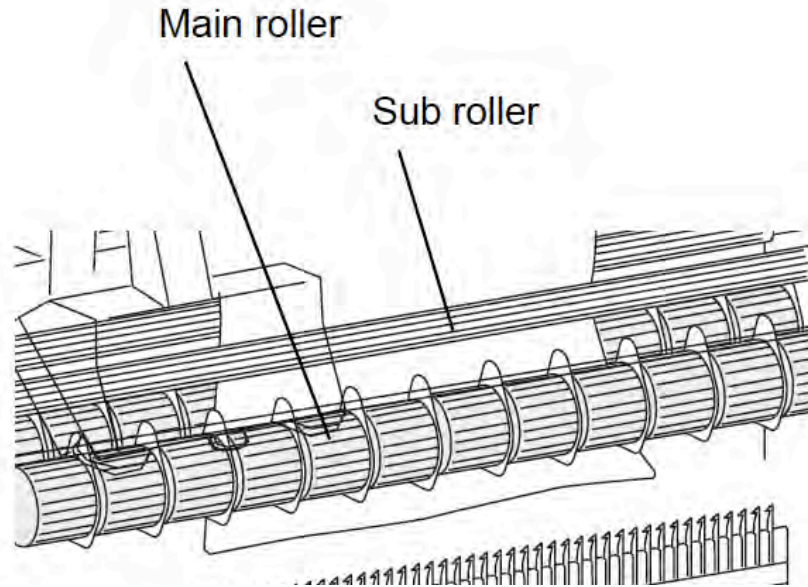

(we don't have set up needle)

1) Set up needle activates.

2) Set up needle activates.

3) Sub roller, main roller activate.

Sub roller

Main roller

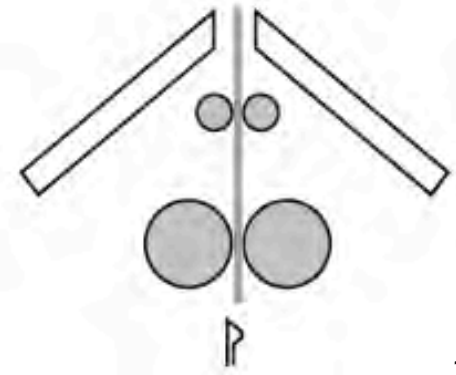
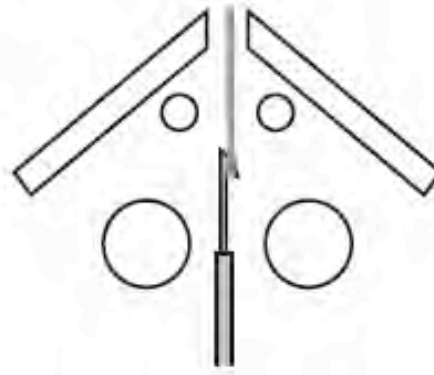
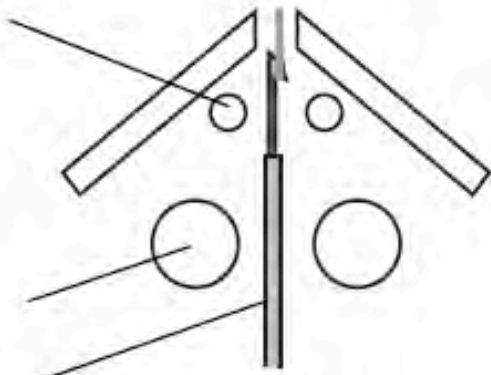

# Shaping Operations: Cables

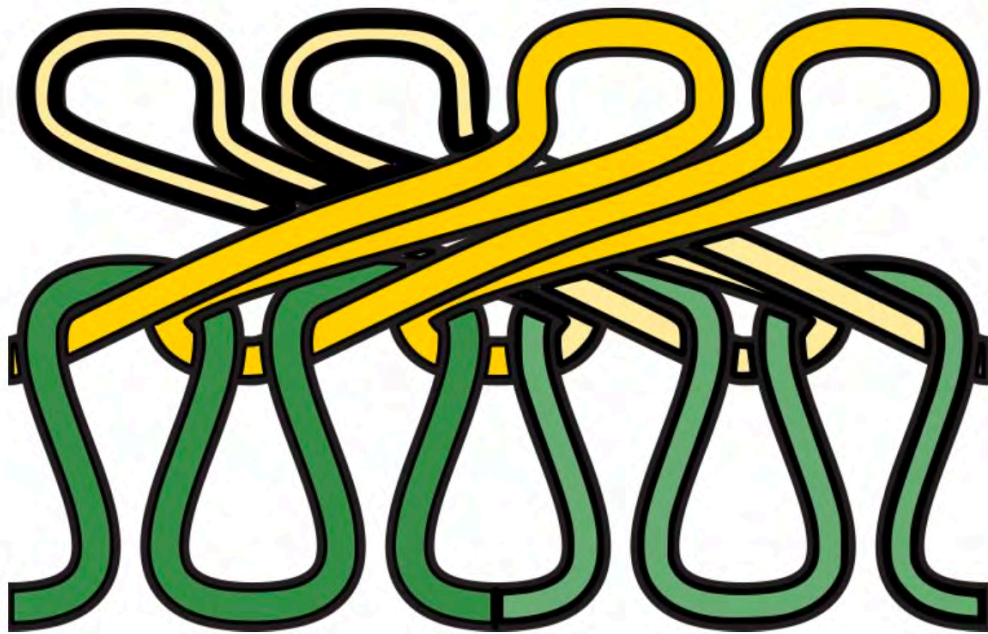

# Cable doesn't change width/height but creates thickness variations

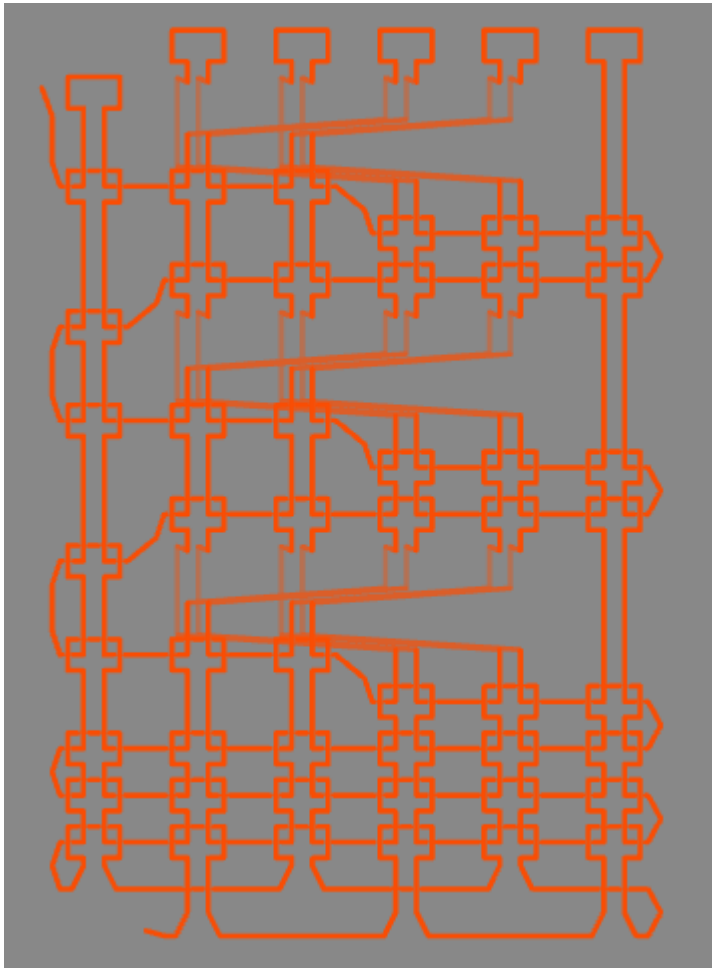

# Tubular Knitting

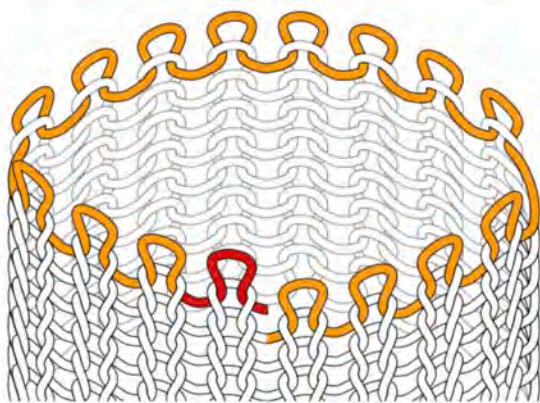

**Knit tubes are made by  
knitting in a spiral**

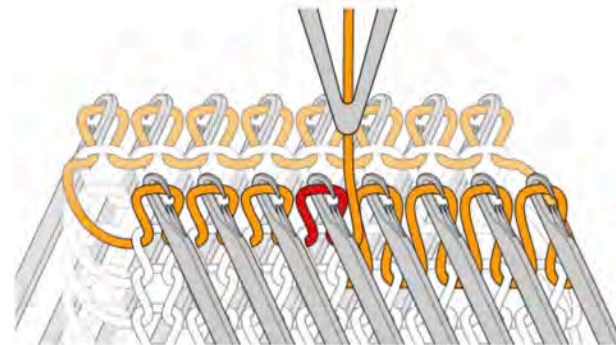

**That tube can be  
flattened to lie on the  
two rows of needles**

# Knit Object Construction

- Basic Geometry: Sheets (Surface), Tubes

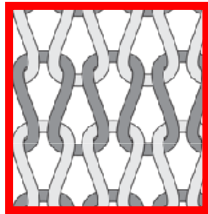

Sheets

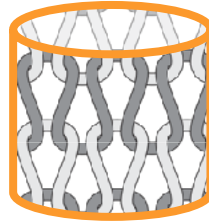

Tubes

- Shaping: increases, decreases, short-rows, cables
  - stitches actually take up space! so the base geometry will be changed locally

# Scarf/Blanket

- A single sheet
- ...

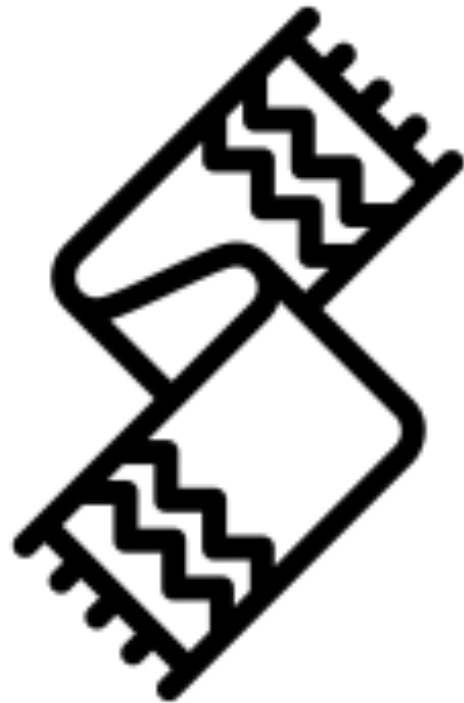

# Beanie

- Tube + decreases up to the top
- ...

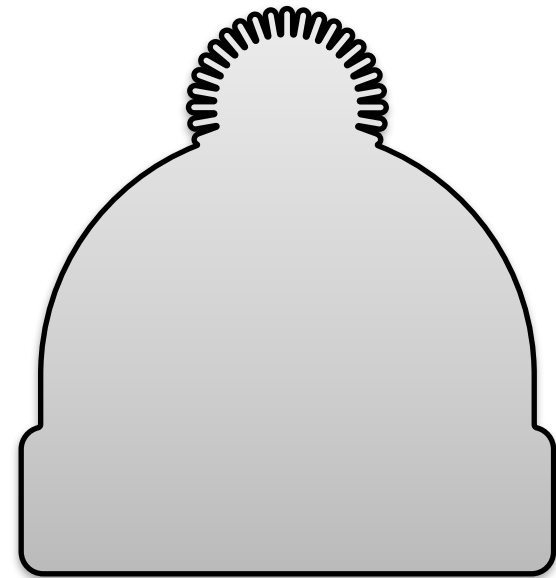

# Sock

- Tube + short-rows at the heel
- ...

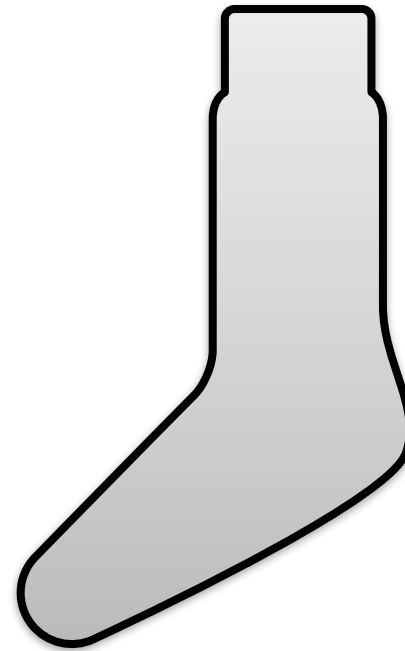

# Sweater

- Three tubes join into one tube, then decreases to a smaller opening for the neck
- ...

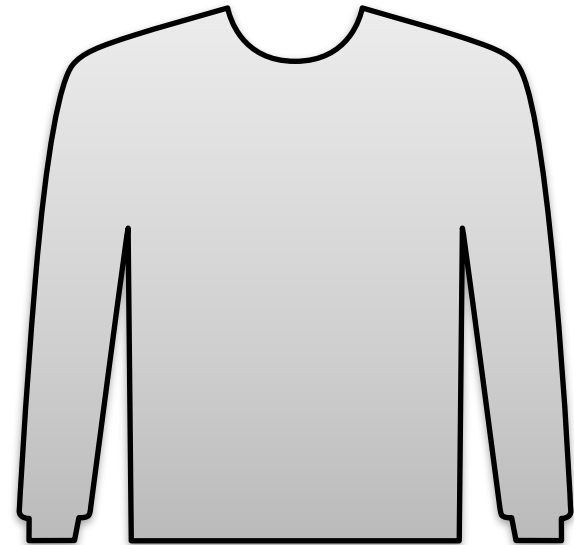

# Teddy Bear

- Tubes for limbs and ears + front and back sheets with increases and decreases, stitched together
- Short-rows for the ears, relying on stuffing material to make the ear bulge out
- ...

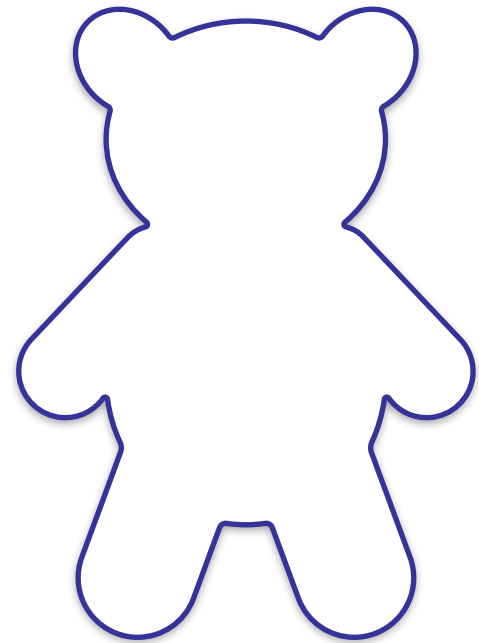

# Back to tubular knitting, what if...

- we want to do knit/purl texture on a tube?
- we want to do colorwork on a tube?
- we want to do both knit/purl texture and colorwork? and on a tube?

# What if...

- **we want to do knit/purl texture on a tube?**
- we want to do colorwork on a tube?
- we want to do both knit/purl texture and colorwork? and on a tube?



# Half Gauging

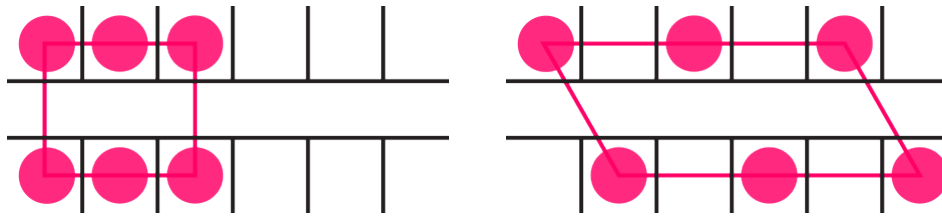

**We can skip some needles when knitting on the machine**

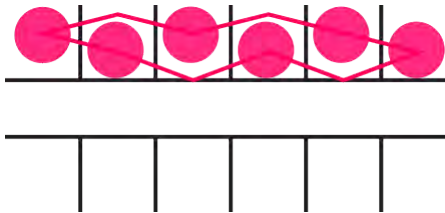

**Sheet stacking is reversible so long as no stacks are made**

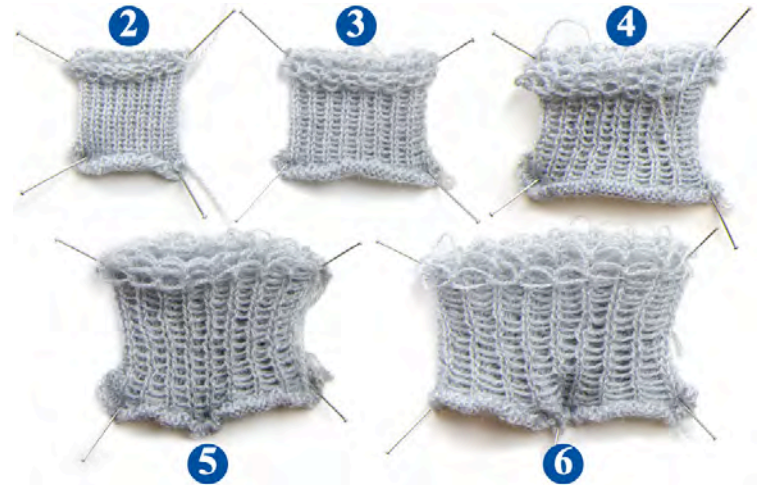

Hoffman, M., et al. UIST (2023).

**Fractional gauging can be extended to layer even more “sheets”**

# What if...

- we want to do knit/purl texture on a tube?
- we want to do colorwork on a tube?
- we want to do both knit/purl texture and colorwork? and on a tube?

# What if...

- we want to do knit/purl texture on a tube?
- **we want to do colorwork on a tube?**
- we want to do both knit/purl texture and colorwork? and on a tube?

# Recap: Machine Colorwork: Plating

Easy to write code for  
Multiple yarns make a thick fabric  
Prone to bleed through and color errors

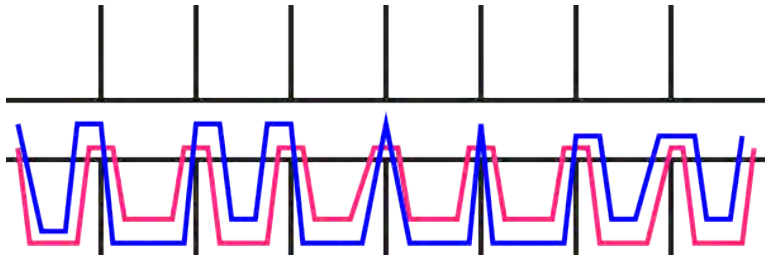

knit + f1 1 2  
knit + f2 2 1  
knit + f3 1 2  
knit + f4 2 1  
knit + f5 2 1  
knit + f6 2 1  
knit + f7 1 2  
knit + f8 1 2



# Recap: Intarsia on Knitting Machine

Hard to write code for  
(especially on tubes!)

Thin fabric

Good for large blocks of color

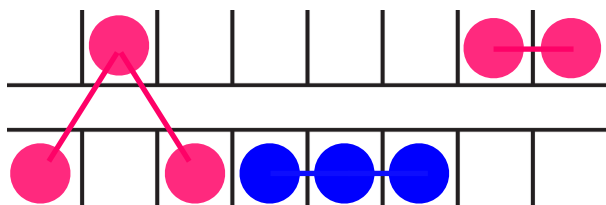

knit + f1 1  
knit + b2 1  
knit + f3 1  
knit + f4 2  
knit + f5 2  
knit + f6 2  
knit + b7 3  
knit + b8 3



# What if...

- we want to do knit/purl texture on a tube?
- we want to do colorwork on a tube?
- we want to do both knit/purl texture and colorwork? and on a tube?

# What if...

- we want to do knit/purl texture on a tube?
- we want to do colorwork on a tube?
- **we want to do both knit/purl texture and colorwork?** and on a tube?

# Illusion Knitting

- <http://www.illusionknitting.woollythoughts.com/>

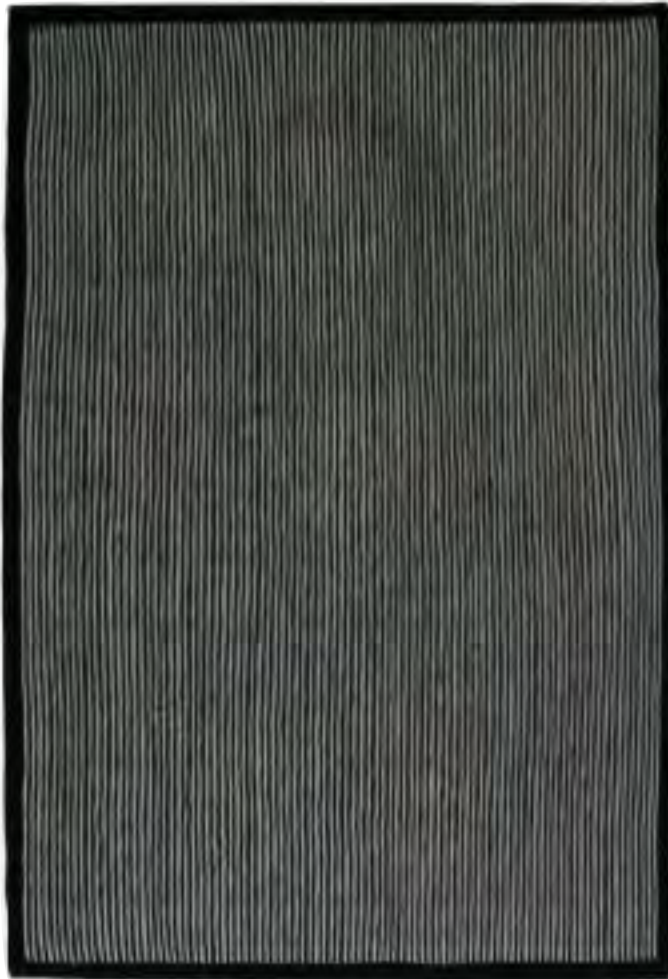

# Illusion Knitting

- <http://www.illusionknitting.woollythoughts.com/>

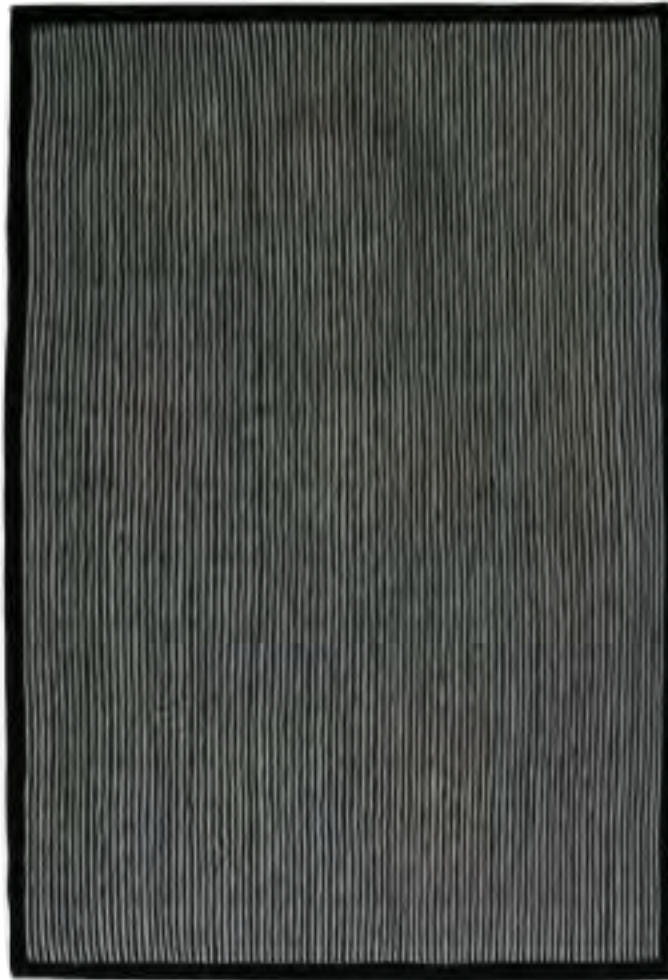

# Poll time: how is the illusion achieved?

- Take a guess

# The special layout: 2-row ridges of knit-knit or knit-purl, always alternating colors

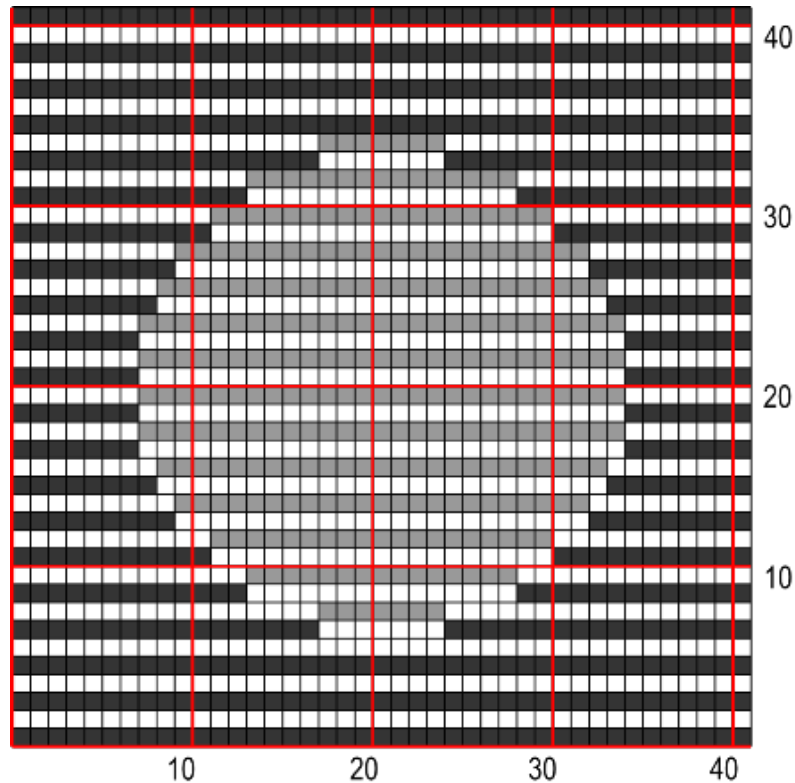

**“On the chart, white stitches are purl, coloured stitches are knit, using the colour for the stripe you are working.”**

# Recap: Basic Unit in Knitting

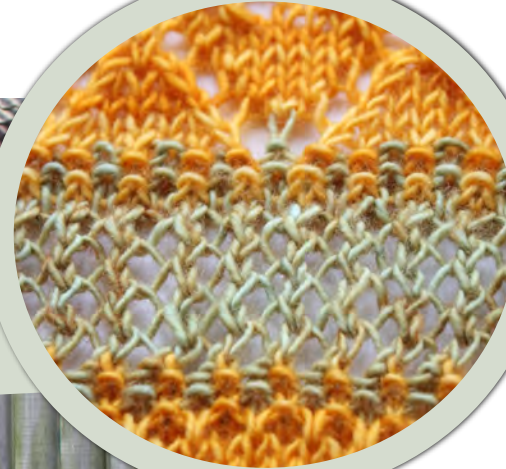

Stitch

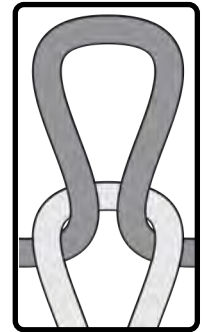

# Recap: Knit Stitch vs Purl Stitch

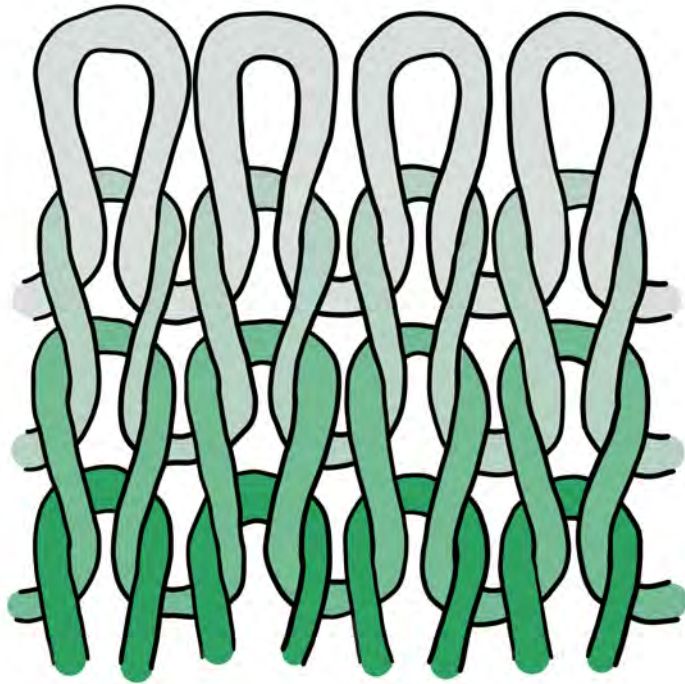

Knit

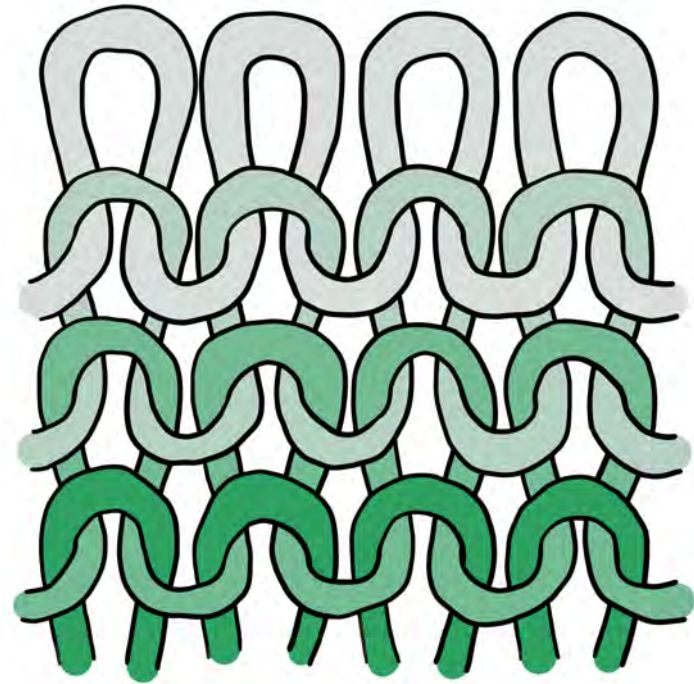

Purl

# Stitch -> Yarn Path

- The stitches might be on a flat surface, but looking closer at the yarn paths, the local thickness is changing.
- Therefore, viewing at a slanted angle, the thicker regions will **occlude** the thinner regions.

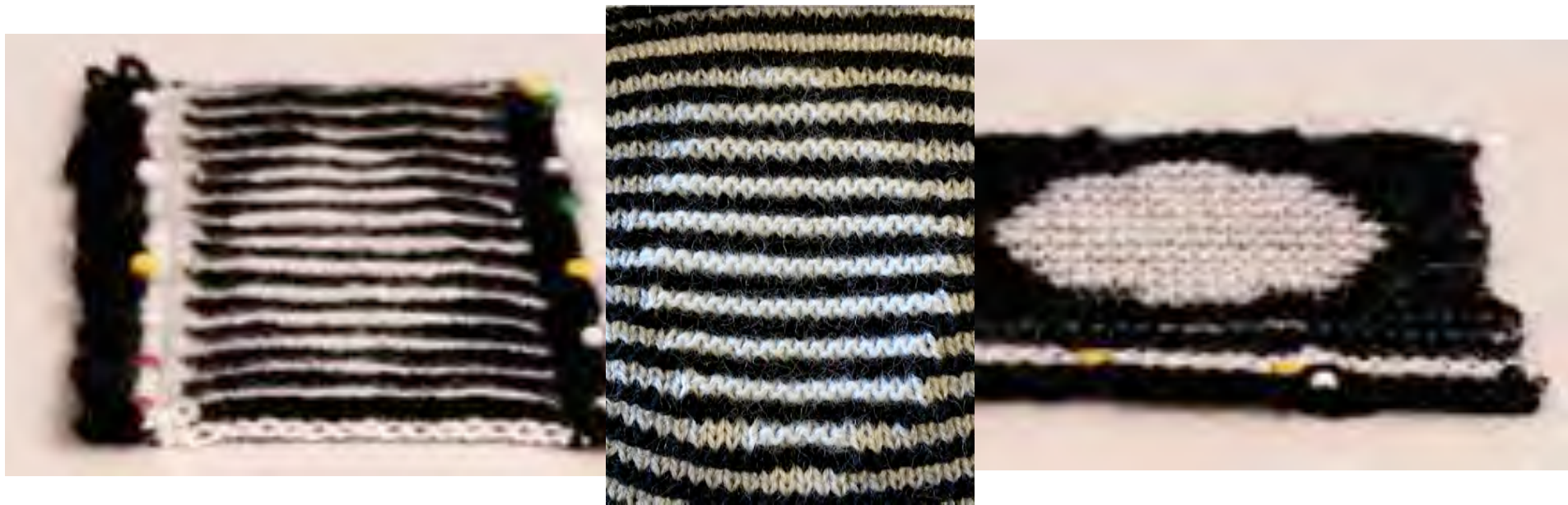

# The effect varies with number of stitches

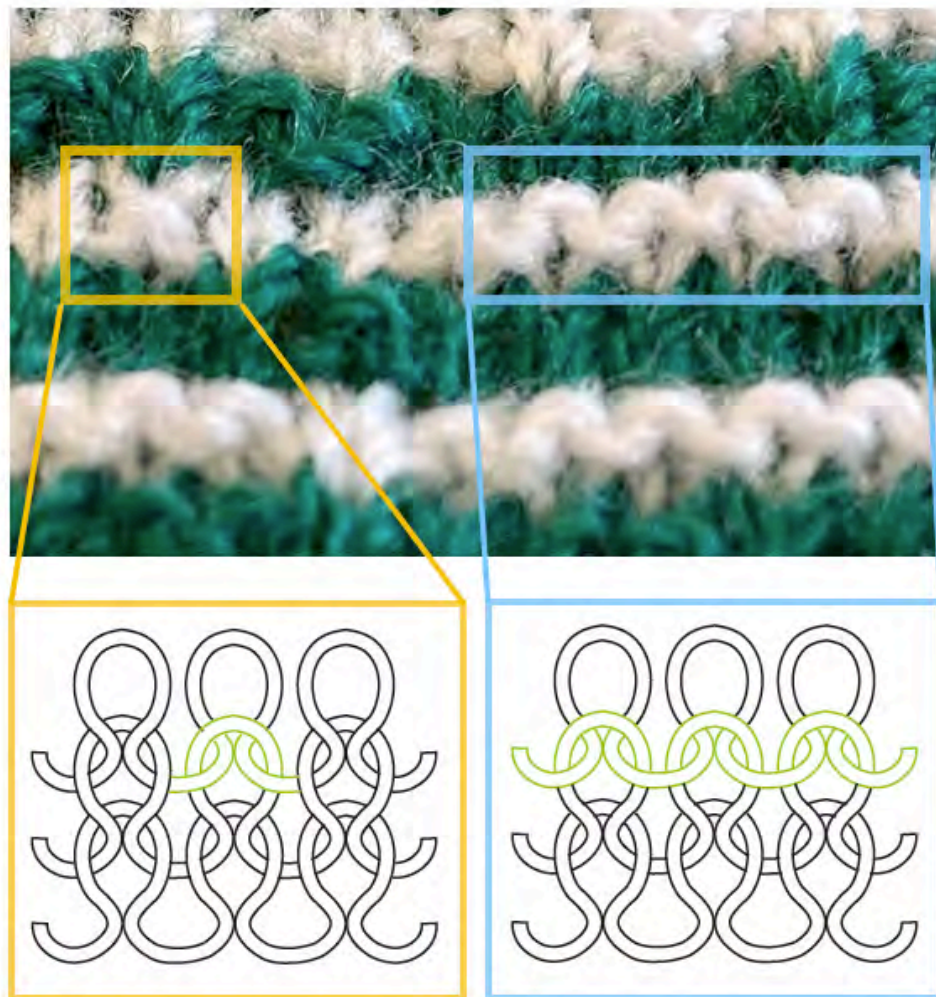

The height of a 1-wide purl bump is greatly diminished when its legs are pulled under the next stitch.

When next to other purls, the legs stand above the fabric.

# What about embedding more than one image into the illusion?

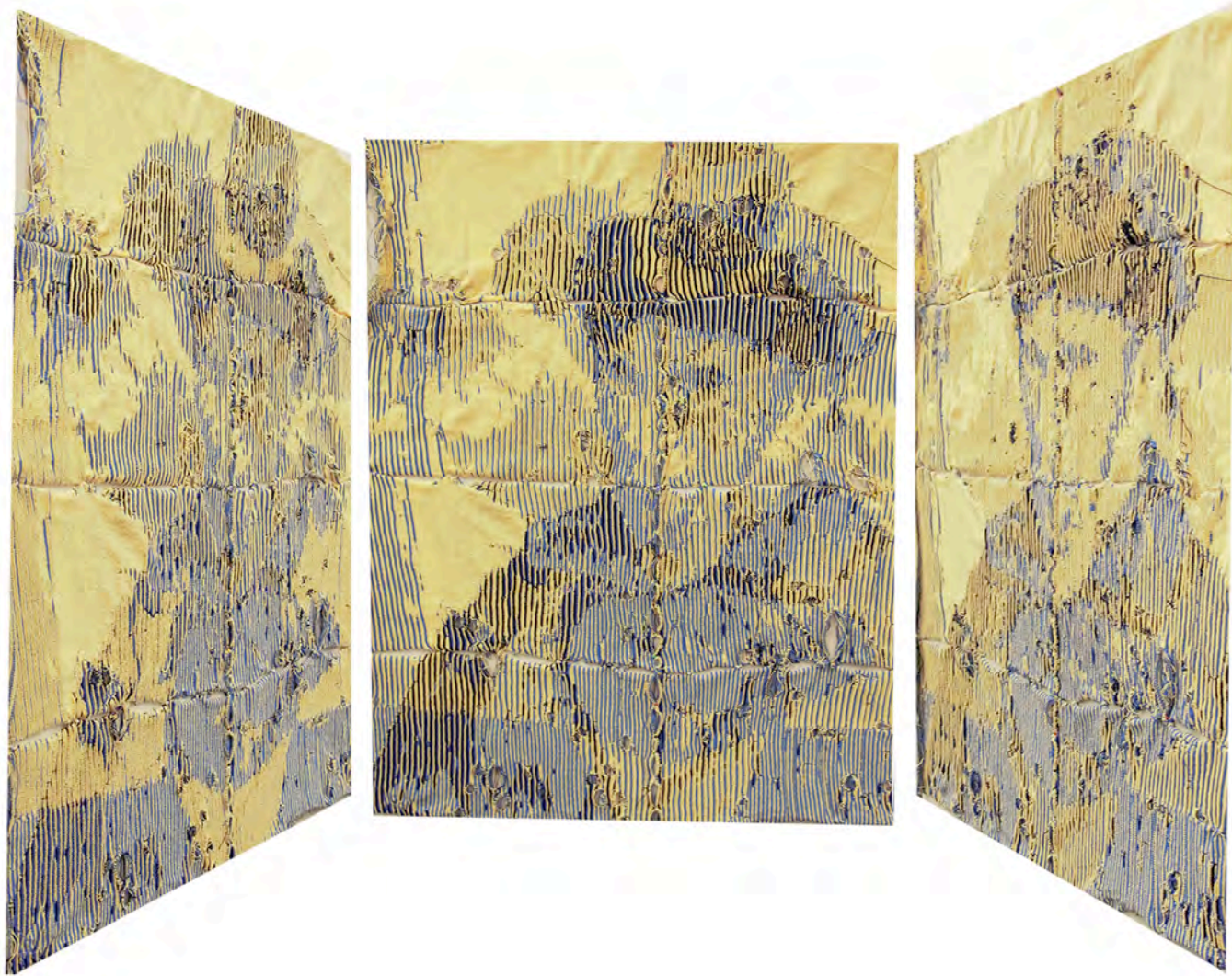

# Computational Illusion Knitting Pipeline

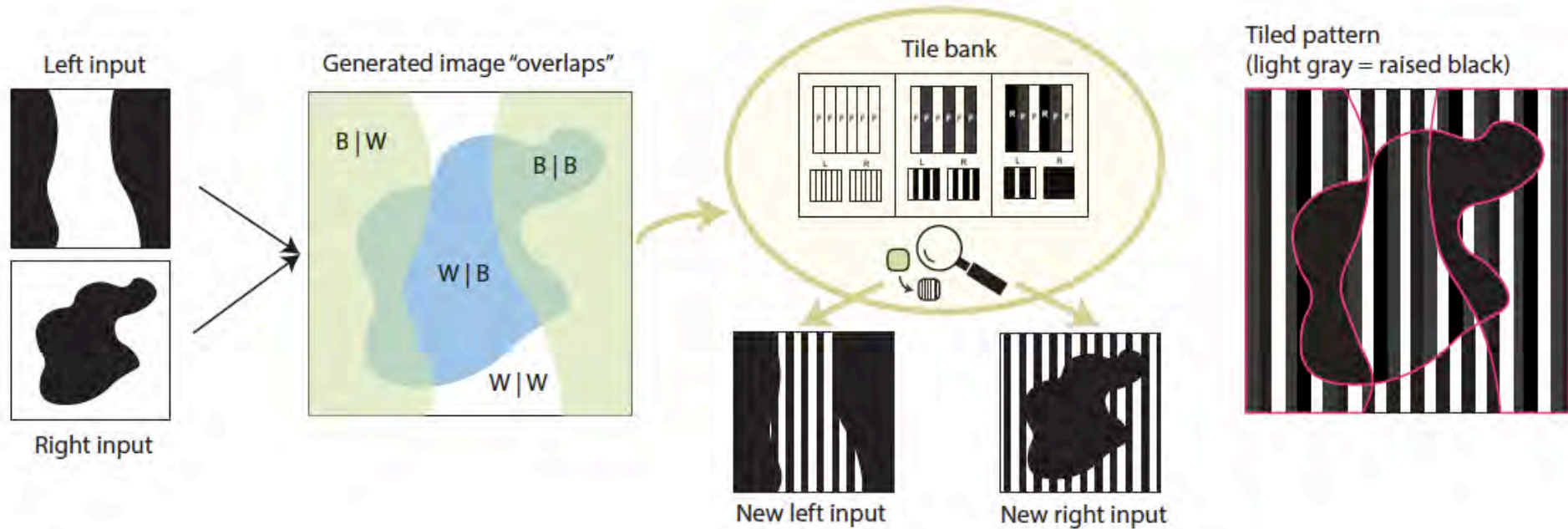

# Special Type of Head-on View + Side View



dragon in a circle

# More Double-Image Examples

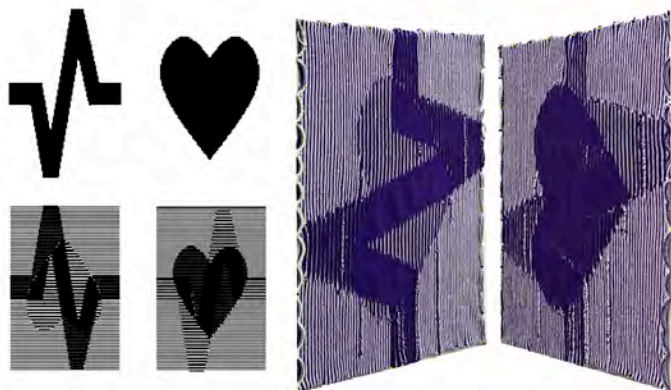

(a) ECG pulse and heart

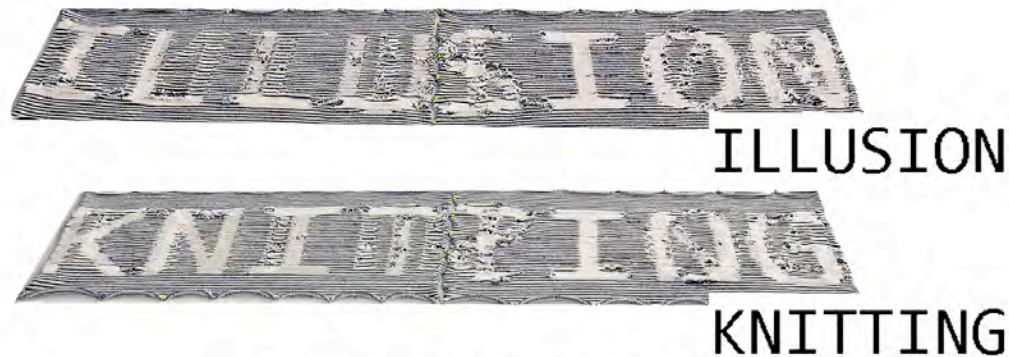

(b) the text ILLUSION and KNITTING



(c) SIGGRAPH and SIGGRAPH Asia Logos

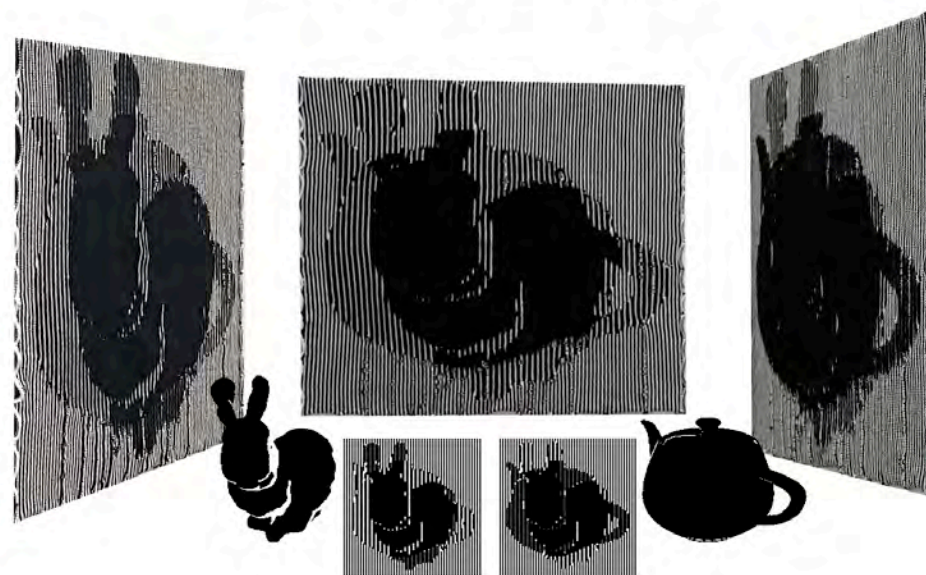

(d) Utah teapot and Stanford bunny

# How are colorwork and texture handled at the same time?

- Single-image Illusion
  - the two colors have to alternate in each ridge, so you can think of the top view as always stripes, and there is not really using both yarns in a single row (no need of colorwork)
- Double-image Illusion
  - the custom tile banks and the shared top view made it impossible to keep the nicely separated stripes, so there is a need to mix colorwork in each row that also has knits and purls
  - Different algorithms to avoid floats in front of pattern, handle yarn catching and anchoring are proposed